

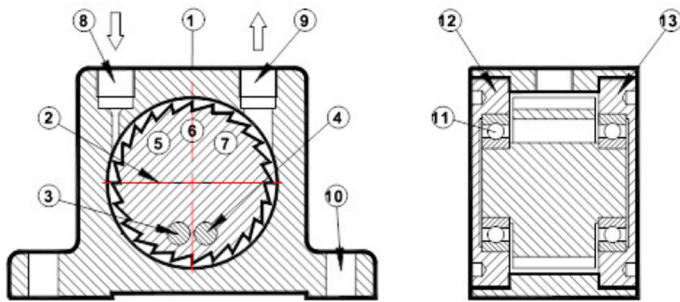

Aluminium Body with Painted Finish *
Anodised Finish available on some models
Rotary Vibrator
Frequency / Force adjustable by air pressure
Suitable for temperature from -40°C to +120/150°C
Noise level 60-70 dB(a) with silencer fitted
Force 130 N to 12000 N

On request can be supplied with ATEX certification to ATEX 2014/34/EU **Ex** II 2 G & D Zone 1, 2 & 21, 22

CONSTRUCTION



Drawing no 075001

1. Extruded Aluminium Alloy Body
2. Hard Coated Aluminium Turbine Wheel
- 3/4. High Density Mass Positive Movement
- 5-7. Cavities Giving Negative Moment
8. Air Inlet
9. Air Exhaust
10. Base Mounting Holes
11. Special Pre-Lubricated Matched Sealed Bearings
- Hard Coated Aluminium Endplates**
12. With Left Hand Thread
13. With Right Hand Thread

PERFORMANCE DATA

Models		Frequency V.P.M.			Centrifugal Force						Air Consumption / Minute					
Standard Painted	Anodised	2 Bar 29 PSI	4 Bar 58 PSI	6 Bar 87 PSI	2 Bar N	29 PSI lbs	4 Bar N	58 PSI lbs	6 Bar N	87 PSI lbs	2 Bar litr	29 PSI CF	4 Bar litr	58 PSI CF	6 Bar litr	87 PSI CF
-	GT04 *	14000	15000	15000	135	30	180	40	200	45	33	1.2	58	2	83	2.9
-	GT06 *	11500	12000	12500	130	29	175	39	210	47	33	1.2	58	2	83	2.9
GT08	GT08A	36000	42000	46000	990	223	2060	463	2910	654	46	1.6	80	2.8	112	3.9
GT10	GT10A	27500	35000	37500	840	189	1390	312	2400	540	46	1.6	80	2.8	112	3.9
GT10S	GT10SA	17000	23000	25000	650	146	1350	303	1950	438	46	1.6	80	2.8	112	3.9
GT13	GT13A	26000	30000	33000	1400	315	2440	549	3730	839	120	4.2	200	7.0	290	10.2
GT16	GT16A	17000	21500	24000	1220	275	2090	470	3160	710	120	4.2	200	7.0	290	10.2
GT16S	-	11500	15500	17000	1100	248	1900	427	2700	607	120	4.2	200	7.0	290	10.2
GT20	GT20A	17000	20000	23000	2170	488	4040	908	5520	1241	185	6.5	325	11.4	455	16.1
GT25	GT25A	12000	15500	17000	2120	477	3510	789	5070	1140	185	6.5	325	11.4	455	16.1
GT25S	-	8500	11000	13000	2250	506	3600	809	4900	1102	185	6.5	325	11.4	455	16.1
GT30	GT30A	13000	14000	16000	3380	760	5430	1221	7540	1695	330	11.7	530	18.7	745	26.3
GT36	GT36A	8000	10000	13000	3290	740	5360	1205	7190	1616	330	11.7	530	18.7	745	26.3
GT36S	-	6100	7200	8300	4100	922	6200	1394	7500	1686	330	11.7	530	18.7	745	26.3
GT40	-	7700	8800	9500	4300	967	7300	1641	9800	2203	425	15	700	24.7	970	34.2
GT48	-	6000	7500	9700	4900	1102	7700	1731	10500	2360	425	15	700	24.7	970	34.2
GT48S	-	-	5600	6300	-	-	7500	1686	12000	2698	-	-	700	24.7	970	34.2

Data obtained on a heavy laboratory test block. Frequency and force will decrease on a less rigid mounting while the noise level will increase.

* GT04 & GT06 only supplied anodised

VIBRATECHNIQUES LTD

20 Cecil Pashley Way, Shoreham Airport, Shoreham by Sea, West Sussex, BN43 5FF

Tel: +44 (0)1273 430977 Fax: +44 (0)1273 430978 Email: sales@vibtec.com Web: www.vibtec.com

ROTARY PNEUMATIC VIBRATOR

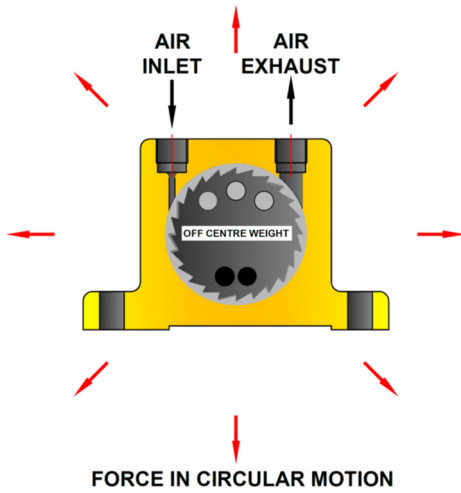

DIMENSIONS

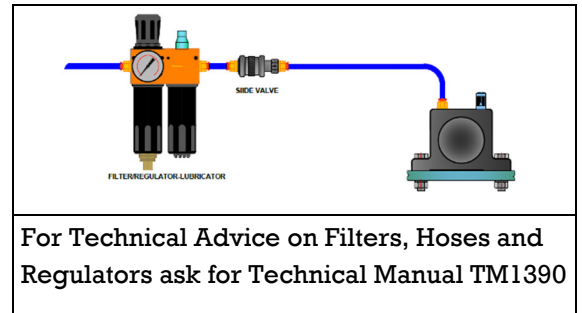
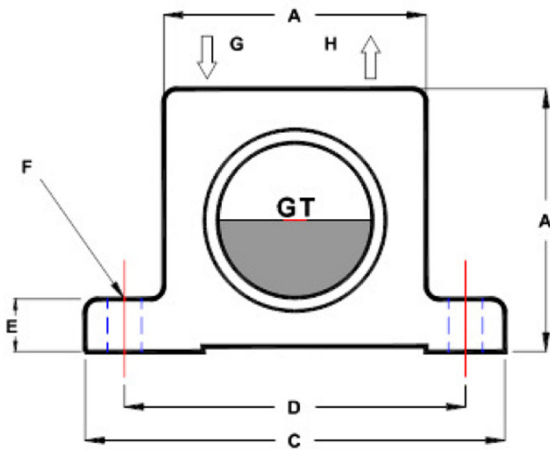

Drawing No 075002

Models		Temp	A		B (Width)		C		D		E		F (Hole Dia)		G/H	Weight	
Painted	Anodised		mm	inch	mm	inch	mm	inch	mm	inch	mm	inch	mm	inch	BSP	kg	lbs
-	GT04 *	150°C	40	1.57	28	1.10	70	2.75	56	2.20	10.5	0.39	6	0.23	1/8"	.167	.37
-	GT06 *	150°C	40	1.57	28	1.10	70	2.75	56	2.20	10.5	0.39	6	0.23	1/8"	.161	.35
GT08	GT08A	120°C	50	1.97	33	1.30	86	3.38	68	2.68	12	0.47	7	0.27	1/8"	.255	.56
GT10	GT10A	120°C	50	1.97	33	1.30	86	3.38	68	2.68	12	0.47	7	0.27	1/8"	.258	.57
GT10S	GT10SA	120°C	50	1.97	33	1.30	86	3.38	68	2.68	12	0.47	7	0.27	1/8"	.270	.59
GT13	GT13A	120°C	65	2.56	42	1.65	113	4.45	90	3.54	16	0.63	9	0.35	1/4"	.555	1.22
GT16	GT16A	120°C	65	2.56	42	1.65	113	4.45	90	3.54	16	0.63	9	0.35	1/4"	.566	1.25
GT16S	-	120°C	65	2.56	42	1.65	113	4.45	90	3.54	16	0.63	9	0.35	1/4"	.603	1.33
GT20	GT20A	120°C	80	3.15	56	2.20	128	5.04	104	4.09	16	0.63	9	0.35	1/4"	1.076	2.37
GT25	GT25A	120°C	80	3.15	56	2.20	128	5.04	104	4.09	16	0.63	9	0.35	1/4"	1.112	2.45
GT25S	-	120°C	80	3.15	56	2.20	128	5.04	104	4.09	16	0.63	9	0.35	1/4"	1.193	2.62
GT30	GT30A	150°C	100	3.94	73	2.87	160	6.30	130	5.12	20	0.79	11	0.43	3/8"	2.201	4.84
GT36	GT36A	150°C	100	3.94	73	2.87	160	6.30	130	5.12	20	0.79	11	0.43	3/8"	2.301	5.06
GT36S	-	150°C	100	3.94	73	2.87	160	6.30	130	5.12	20	0.79	11	0.43	3/8"	2.525	5.56
GT40	-	150°C	120	4.72	86	3.26	194	7.63	152	5.98	24	0.94	17	0.66	3/8"	3.696	8.13
GT48	-	150°C	120	4.72	86	3.26	194	7.63	152	5.98	24	0.94	17	0.66	3/8"	3.858	8.49
GT48S	-	150°C	120	4.72	86	3.26	194	7.63	152	5.98	24	0.94	17	0.66	3/8"	4.274	9.40

Data obtained on a heavy laboratory test block. Frequency and force will decrease on a less rigid mounting while the noise level will increase.

* GT04 & GT06 only supplied anodised