

■ IM-VM-VMS

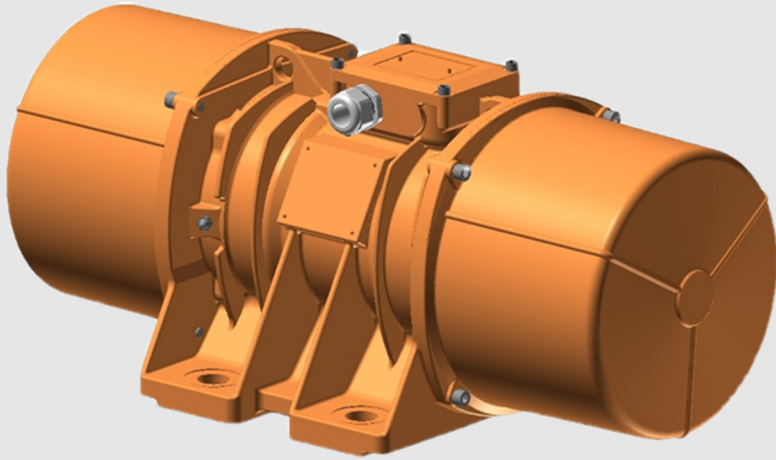

Technical features

Standard painting

Electrostatic surface treatment for all external components based on polymerised epoxy polyester powder in oven at 200°C.

Good resistance versus corrosion in normal operating conditions.

Salt spray tested for 500 hours.

IM-VM-VMS ELECTRIC EXTERNAL VIBRATORS WITH ALTERNATIVE HOLE FIXINGS (ALTERNATIVE REPLACEMENT PARTS)

Ring the Technical Department for details

VIBRATECHNIQUES LTD

20 Cecil Pashley Way, Shoreham Airport, Shoreham by Sea, West Sussex BN43 5FF United Kingdom

Tel: +44 (0) 1273 430977 Fax: +44(0) 1273 430787 Web: www.vibtec.com E-mail: sales@vibtec.com

■ IM-VM-VMS

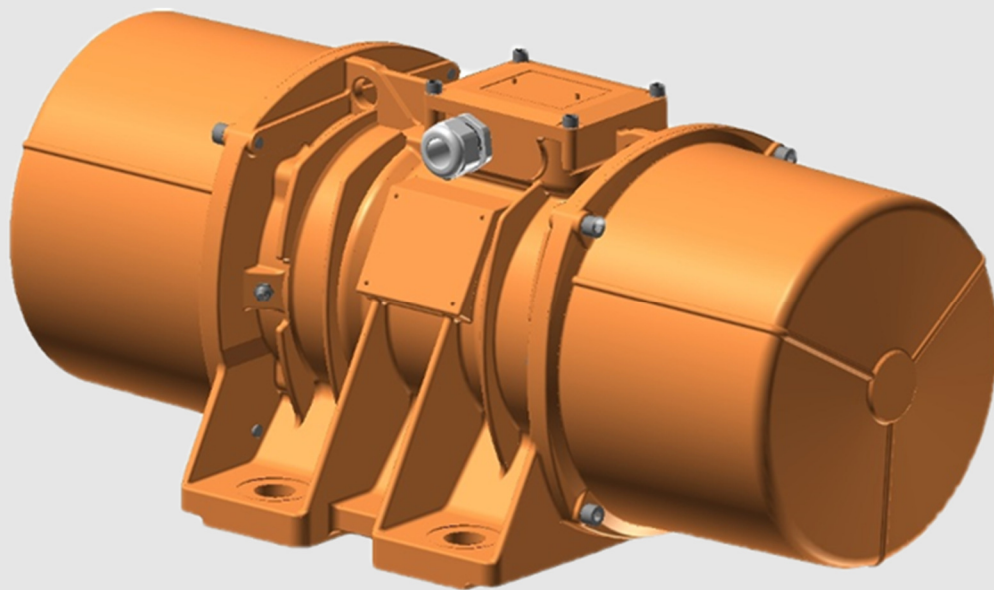

Technical features

Power supply

Three-phase voltage from 24V to 690V, 50Hz or 60Hz or single-phase 100-130V, 60Hz and 200-240V, 50Hz (single-phase types are supplied without capacitor); suitable for use with an inverter from 20Hz to the base frequency with constant torque load profile.

Polarity

2, 4, 6 and 8 standard poles, 10 and 12 poles on request.

Conformity with Standards and Regulations

Low Voltage Directive 2006/95/EC; ATEX Directive 2014/34/UE; EN/IEC 60034-1, EN/IEC 60079-0, EN/IEC 60079-31, UL 1004-1, CSA C22.2 No.100, NEMA MG-1.

Functioning

Continual service (S1) at maximum declared centrifugal force and electric power. Intermittent services are also possible depending on the type of vibrator and the operating conditions. For detailed information, contact our technical assistance office.

Centrifugal force

Range extended up to 30500 kgf. (300 kN), with centrifugal force adjustable by varying eccentric weights position.

Mechanical protection

IP 66 according to IEC/EN 60529.

Protection against mechanical impacts

IK 08 according to IEC/EN 62262.

Insulation class

Class F (155°C), class H (180°C) on request.

Tropicalization

Standard on all vibrators, with vacuum encapsulation up to gr. AF 33 and 35, with "drop by drop" trickle system for larger sizes.

Ambient temperature

From -20°C to +40°C. Versions for higher or lower temperatures are available on request.

Vibrator thermal protection

Standard PTC rated thermistor heat detectors 130°C from size 70, on request for smaller sizes. On request, thermistors with different temperatures and anti-condensation heaters.

Fixing of the vibrator

In all positions and therefore without restriction.

Lubrication

All vibrators are lubricated in the factory and do not require further lubrication at start-up.

Terminal box

Large terminal box to facilitate electrical connection.

Special shaped terminals allow for the power supply cable to be secured, whilst protecting it from loosening.

Electric motor

Three-phase asynchronous type. Designed for maximum starting torques and torque curves specific to requirements of vibrating machines. Insulated windings using vacuum encapsulating up to sizes AF33 and 35 included; using the "drop by drop" trickle system with class H resin for larger sizes. The rotor is die cast aluminium.

Casing

In high-tensile aluminium alloy up to size 60, in spheroidal cast iron for larger sizes.

Bearing flange

In cast iron (spheroidal or grey). The geometry of the flange transmits the load to the casing uniformly.

Bearings

Custom made with particular geometry, especially designed for Italtibras, suitable to support both high radial and axial loads.

Motor shaft

In treated steel alloy (Isothermic hardening) resistant to stress.

Eccentric weights

Allow adjustment of the centrifugal force. This adjustment is realized by a graduated scale, which expresses the centrifugal force as a percentage of the maximum centrifugal force.

A patented system, called ARS, prevents adjustment errors.

■ IM-VM-VMS

The MVSI series represents the line of reference products for manufacturers of vibrating machines and plants operating in many industrial sectors and is made up of the largest range on the market, with centrifugal force values up to 30500 Kg (300kN).

It is characterized by the continuous technological evolution in view of a continuous improvement in performance.

The MVSI series is designed to guarantee high performance in all conditions of use and environment, on page 14 the various surface treatments available are described.

Category: II2D

Level of protection:

Ex tD A21 T...°C IP66 (Ex tb IIIC T...°C Db)

Temperature class:

see tables

UE certificate:

LCIE 05 ATEX 6163 X

Zones of use:

21, 22

Weight covers

Standard in aluminium alloy, on request stainless steel weight cover in AISI 304 may be available. See also executions on page 14. Split weight cover are available for many types, see MVSI-TS series.

Painting / Surface coating

Electrostatic surface treatment based on epoxy polyester powder polymerised in oven at 200°C. Tested in salt spray for 500 hours. On request on MVSI series other surface coatings may be available, see page 14. Available also MVSS series with external components in stainless steel AISI 304, see page 40.

Other mounting bolt patterns are available.

For further details please contact sales offices at Italtvibras.

The technical data and models listed in this catalogue are not binding. Italtvibras reserves the right to modify them without prior notice.

Certifications



Compliance with the applicable European Union directives.



Standard CAN/CSA – C22.2, N°.100-95, Certificate n° LR 100948
Class 4211 01 - Motors and generators
UL 1004-1 – Rotating Electrical Machines – General Requirements
Class II Div.2, Groups FG (T3B)



II2D (2014/34/UE)
Ex tD A21 T...°C IP66 (Ex tb IIIC T...°C Db)
EN 60079-0
EN 60079-31



Ex tD A21 T...°C IP66 (Ex tb IIIC T...°C Db)
IEC 60079-0
IEC 60079-31



Version MVSI-F available on request
Class II Div.1, Groups EFG
Standard CAN/CSA – C22.2, UL 1004-1



Version MVSI-C available on request
Class I Div.2, Groups ABCD
Standard CAN/CSA – C22.2



Certification for Eurasian Customs Union
N° TC N RU Д-ИТ.АЛ33.В.02527
N° TC RU C-ИТ.ГБ08.В.02190



KOSHA Korea
Certificate n° 11-AVG BO-0359
Ex td A21 IP66